



ASSEMBLY GUIDE

168435-xxx-xx

Railing base

EASY GLASS® PRIME FASCIA CLADDING - adhesive tape mounting instructions

Q-INFO MOD 8435

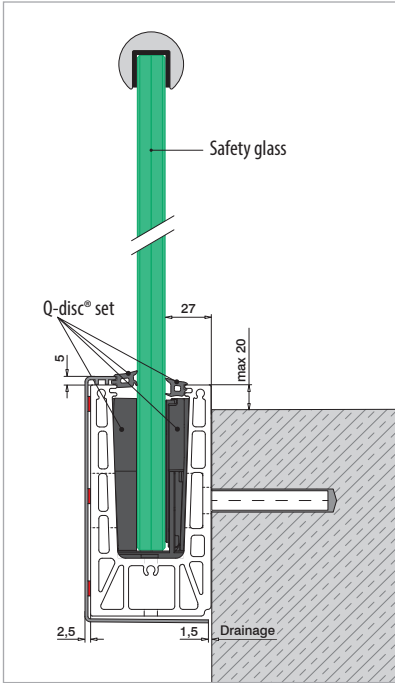

168435-xxx-18, follow installation steps starting at P3

Included
168435-xxx-xx

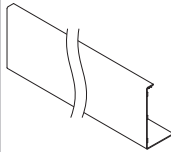

168435-xxx-00, follow installation steps starting at P1

Order additionally
201360 (= ± 33 mtr = ± 11 mtr cladding)
Q-53

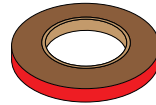

Please do any surface treatments before these preparations steps

P1

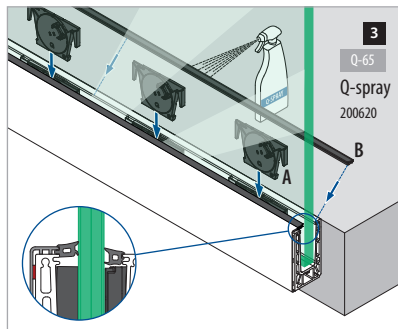
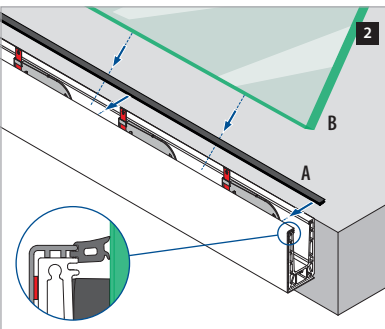
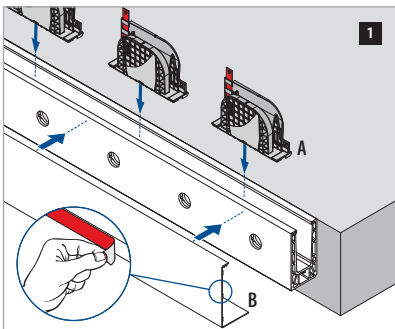
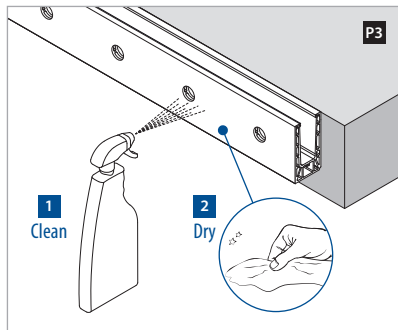
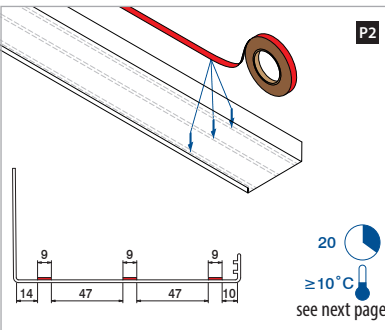
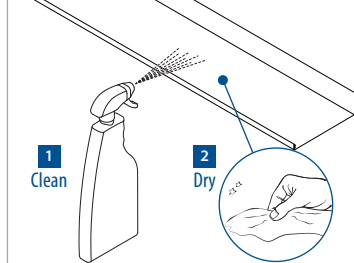

Railing base

EASY GLASS® PRIME FASCIA CLADDING - adhesive tape mounting instructions - Alternative mounting option

Q-INFO MOD 8435

Before mounting onto base shoe, consider preparation steps (P)

P

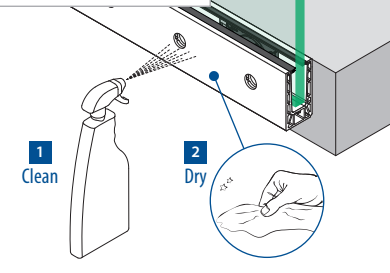

1

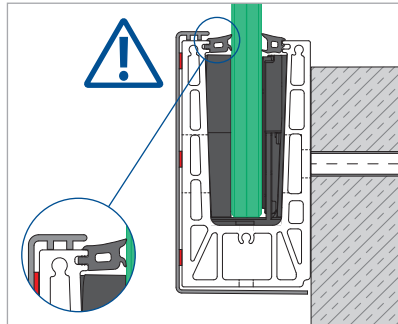
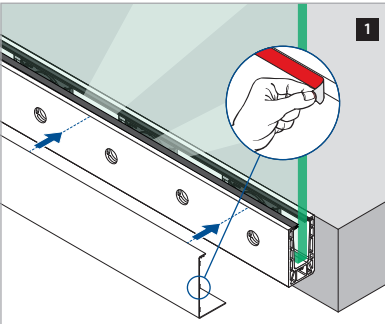



3M™ VHB™ Tapes

Applications

- For bonding high surface energy materials such as metals, painted surfaces, painted wood, glass, ceramics and many plastics.
- For indoor and outdoor use

Surface Preparation

- Ensure that surfaces to be bonded are well unified, clean, dry and free of grease and dust. Clean them with benzene or isopropyl alcohol (do not use moisturizing household cleaners)
- On glass surfaces, always use 3M Silane Glass Primer (follow the product's instructions for use)

Instructions for Use

- The recommended amount of tape per kg to be held is at least 60 cm² for outdoor applications and at least 25 cm² for indoor applications (standard values)
- Best to apply at temperatures between 15 °C and 25 °C
- Apply the tape and press on firmly (min. 2 kg/ cm²)
- Remove the liner and apply the second part to be bonded
- Do not touch the adhesive. Avoid trapped air pockets
- Position the tape carefully; it cannot be repositioned due to its high bonding strength.
- Apply pressure to the second part to be bonded (min. 2 kg/ cm²)

Final Strength

- The tape reaches its final strength after 72 hours at 20 °C. Do not apply loads before final strength has been achieved, and keep the parts to be bonded free of any loading during this time

Important

- Do not use on low surface energy materials such as PE, PP, PTFE, PA or on difficult-to-bond surfaces such as rubber or silicone
- Overhead bonding is not recommended
- For further information, please refer to the technical bulletin for the particular product

Time:

After application, the bond strength will increase as the adhesive flows onto the surface (also referred to as "wet out"). At room temperature approximately 50% of ultimate bond strength will be achieved after 20 minutes, 90% after 24 hours and 100% after 72 hours. This flow is faster at higher temperatures and slower at lower temperatures. Ultimate bond strength can be achieved more quickly (and in some cases bond strength can be increased) by exposure of the bond to elevated temperatures (e.g. 150°F [66°C] for 1 hour). This can provide better adhesive wetout onto the substrates. Abrasion of the surfaces or the use of primers/ adhesion promoters can also have the effect of increasing bond strength and achieving ultimate bond strength more quickly.

Temperature:

Ideal application temperature range is 70°F to 100°F (21°C to 38°C). Pressure sensitive adhesives use viscous flow to achieve substrate contact area. Minimum suggested application temperature: 50°F (10°C)

Note:

Initial tape application to surfaces at temperatures below these suggested minimums is not recommended because the adhesive becomes too firm to adhere readily. However, once properly applied, low temperature holding is generally satisfactory. To obtain good performance with all 3M™ VHB™ Tapes, it is important to ensure that the surfaces are dry and free of condensed moisture.

All statements, technical information and recommendations contained in this document are based upon tests or experience that 3M believes are reliable. However, many factors beyond 3M's control can affect the use and performance of a 3M product in a particular application, including the conditions under which the product is used and the time and environmental conditions in which the product is expected to perform. Since these factors are uniquely within the user's knowledge and control, it is essential that the user evaluate the 3M product to determine whether it is fit for a particular purpose and suitable for the user's method of application. Except where prohibited by law, 3M will not be liable for any loss or damage arising from the 3M product, whether direct, indirect, special, incidental or consequential, regardless of the legal theory asserted, including warranty, contract, negligence or strict liability.

